

Model B Safesite Sight Flow Indicator Documentation



Assembly Instructions

This unit was assembled at the factory and is ready for installation. The sight glass should be visually checked, for any possible damage during shipping. After the unit has been installed, heated and pressurized several times, it should be inspected to check for any possible leakage. If leakage occurs, follow step (I) until leakage has stopped.

If the lens or packing in the sight glass needs to be replaced after the unit has been in operation, it is suggested that the packing be replaced each time, and the lens be replaced if there are any visual defects in the glass. When installing parts, refer to steps (A) thru (J).

(A) Shut down the operating vessel so there is no pressure in the system where the sight glass is operating. Disassemble the unit by removing the cap screws, cap, lens, packing and cushion gaskets.

(B) The interior of the unit body (3) must be clean.

(C) Place the new bottom cushion gasket (largest I.D.) into position in the unit body (3).

(D) Carefully place the lens on the bottom cushion gasket (1).

(E) Insert the lens packing (4) between the lens (2) and the interior wall of the unit body (3) in a normal packing procedure.

(F) Place the one piece compression ring (5) on the packing (4), bevelled side down.

(G) Place the new top cushion gasket (6) (smallest I.D.) on top of the lens (2) inside of the I.D. of the compression ring (5).

(H) Place the retainer cap (7) into position and install the cap screws (8). Due to the non-compression of the packing (4), the cap may ride on the compression ring (5). If this should occur, tighten the cap screws (8) until the unit (3) and the retainer cap (7) make contact.

(I) Insert the compression adjustment screws (9) and tighten across diameters.

(J) Occasionally, when pressure is applied, the packing (4) will loosen. Should leakage occur, follow the tightening procedure outlined in step (I), until the leakage has stopped.

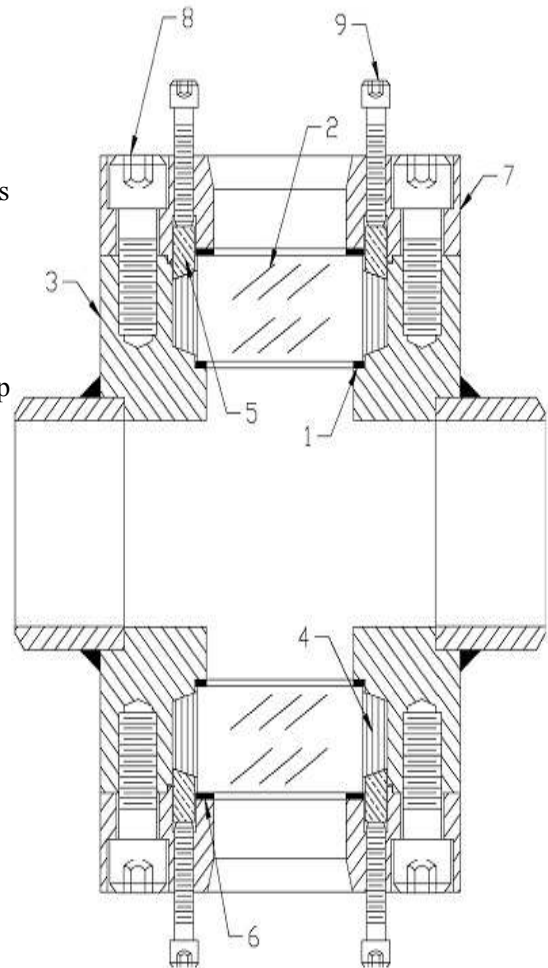

IF THERE ARE ANY QUESTIONS CALL 1-800-624-9043