

# Model A Sight Glass Documentation

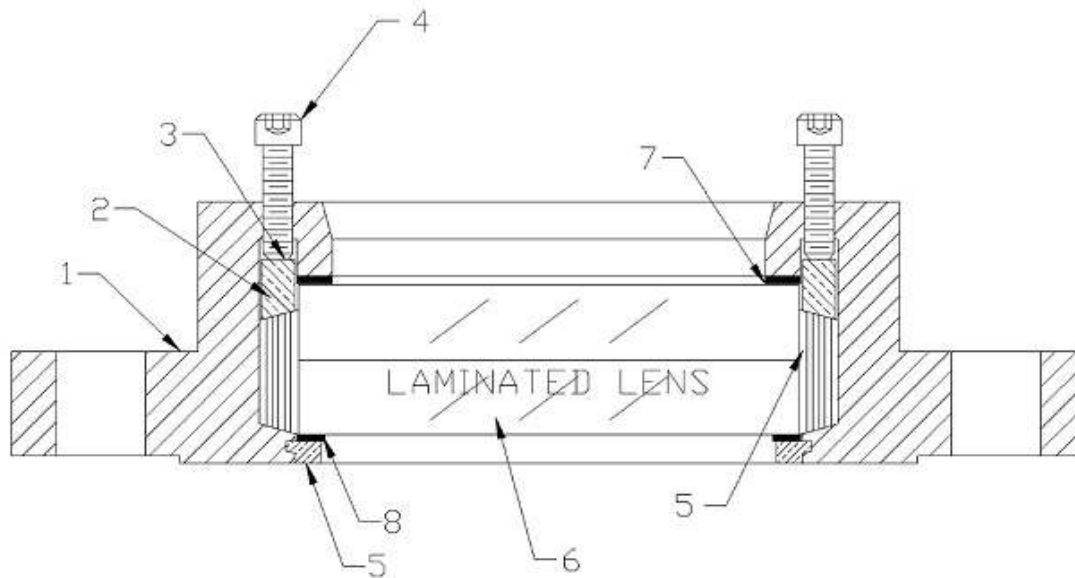

## Assembly Instructions



This unit was assembled at the factory and is ready for installation. The sight glass should be visually checked for any possible damage during shipping. If leakage occurs, follow step (N) until leakage has stopped.

When installing parts, refer to steps (A) thru (P).

- (A) Place the unit (1) on a flat surface, hub down.
- (B) The interior of the unit must be clean.
- (C) Reverse the position of the unit so the flange is on the flat surface.
- (D) Place the three part compression ring (2) through the hub, one section at a time (bevelled side down), so the ring rests at the bottom of the interior wall.
- (E) Insert the snap ring (3) into the grooved area of the three part compression ring.
- (F) Reverse the position of the unit so it rests on the hub as in position (A).
- (G) Carefully slide the compression ring (2) down the hub wall in the counter bore.
- (H) Place the top cushion gasket (7) (smallest ID) on the lens bearing surface of the flange housing and inside the I.D. of the compression ring (2).
- (I) Place the lens packing (9) tightly into place against the interior hub wall in a normal packing procedure.
- (J) Carefully insert the lens (6) so the periphery of the lens does not touch the metallic raised surface.
- (K) The lens (6) must be positioned firmly against the top cushion gasket (7). Place the bottom cushion gasket (8) (largest ID) into position.
- (L) Insert the lens retainer ring (5).

- (M) Reverse the position of the assembled unit with the flange down as in position (C).
- (N) Insert the compression screws (4) and tighten across diameters.
- (O) The unit is now ready for installation.
- (P) Occasionally, when pressure is applied, the packing (8) will loosen. Follow the tightening procedure outlined in step (N), until leakage has stopped.

IF THERE ARE ANY QUESTIONS CALL 1-800-624-9043